



rare plastics

A Division of the Rare Group

Rare Plastics manufacture and distribute HDPE pipe & fittings from our factory in Meyerton, Gauteng. Pipes are manufactured to SANS ISO 4427 standards and sizes range from 110mm to 1000mm. The PE100 raw material is sourced from reputable manufacturers who comply to SANS ISO 4427 Part 1.



Rare is a proud member of SAPPMA (Southern African Plastic Pipe Manufacturers Association), IFPA (Installation and Fabrication Plastics Pipe Association) and the Southern African Society for Trenchless Technology (SASTT).

rare plastics



BENEFITS

HDPE piping systems offer many benefits when compared to most other materials; which typically include the following:

- High impact strength
- Resistance against chemicals, corrosion and abrasion
- Chemically inert and unaffected by acidic soil conditions
- Biologically inert against micro organisms
- Available in long lengths, reducing the number of joints
- Flexibility and toughness
- Inherent resistance to the effect of ground water movement
- Excellent hydraulic properties with low friction resistance throughout life
- Non-toxic and safe for drinking water
- Low installation cost and maintenance free
- Environmentally friendly
- Can be fusion welded, ensuring absolutely leak free joints
- Very suitable for rehabilitation of old pipelines



rare plastics

A Division of the Rare Group

APPLICATIONS

Some typical applications of HDPE pipe include the following:

- Mining (surface and underground)
- Water supply
- Agriculture / irrigation
- High temperature liquids and gases – usually not above 60°C
- Corrosive water and effluents
- Dewatering
- Drainage and sub-soil drainage
- Protection of electrical and telephone cables
- Hydraulic transport
- Pipeline rehabilitation





rare plastics

A Division of the Rare Group

JOINTING METHODS

HDPE allows for a range of jointing systems to suit various applications. Permanent and detachable jointing methods are used, with several options available under each method.

PERMANENT JOINTING



Butt-welding



Electro fusion

DETACHABLE JOINTING



Stub & Flange



Compression fittings



Saddles



Tak and Victaulic system

Mechanical couplings





DIMENSIONS OF PE 100 HDPE PIPES ISO / SANS 4427-2:2008
SDR 7.4 TO SDR 17

SDR RATING PE 100		DIMENSIONS OF PE 100 HDPE PIPES ISO / SANS 4427-2:2008																															
		SDR 17 8						SDR 13.6 10						SDR 11 12.5						SDR 9 16						SDR 7.4 20							
		WALL THICKNESS		NOM		MASS		WALL THICKNESS		NOM		MASS		WALL THICKNESS		NOM		MASS		WALL THICKNESS		NOM		MASS		WALL THICKNESS		NOM		MASS			
min	max	min	max	min	max	min	max	min	max	min	max	min	max	min	max	min	max	min	max	min	max	min	max	min	max	min	max	min	max				
16	16.3																																
20	20.3																																
25	25.3	2	2.15	2.3	20.9	0.149																											
32	32.3	2	2.15	2.3	20.9	0.194																											
40	40.3	2.4	2.6	2.8	35	0.294																											
50	50.3	3	3.2	3.4	43.8	0.453																											
63	63.4	3.8	4.05	4.3	55.1	0.721																											
75	75.5	4.5	4.8	5.1	65.7	1.018																											
90	90.6	5.4	5.75	6.1	78.8	1.463																											
110	110.7	6.6	7	7.4	96.4	2.177																											
125	125.8	7.4	7.85	8.3	109.7	2.777																											
140	140.9	8.3	8.8	9.3	122.9	3.487																											
160	161	9.5	10.05	10.6	140.4	4.551																											
180	181.1	10.7	11.3	11.9	158	5.756																											
200	201.2	11.9	12.55	13.2	175.5	7.103																											
225	226.4	13.4	14.15	14.9	197.4	9.009																											
250	251.5	14.8	15.6	16.4	219.6	11.040																											
280	281.7	16.6	17.5	18.4	245.9	13.870																											
315	316.9	18.7	19.7	20.7	276.6	17.565																											
355	357.2	21.1	22.25	23.4	311.6	22.356																											
400	402.4	23.7	24.95	26.2	351.3	28.253																											
450	452.7	26.7	28.1	29.5	395.2	35.795																											
500	503	29.7	31.25	32.8	439	44.228																											
560	563.4	33.2	34.95	36.7	491.8	55.407																											
630	633.8	37.4	39.35	41.3	553.2	70.175																											
710	716.4	42.1	44.3	46.5	623.4	89.183																											
800	807.2	47.4	49.85	52.3	702.3	113.086																											
900	908.1	53.3	56.05	58.8	789.9	143.050																											
1000	1009.0	59.3	62.35	65.4	877.3	176.796																											

Available RPC Water and Sewer pipes

DIMENSIONS OF PE 100 HDPE PIPES ISO / SANS 4427-2:2008 - SDR 21 TO SDR 41

DIMENSIONS OF PE 100 HDPE PIPES ISO / SANS 4427-2:2008																						
SDR 41 3.2					SDR 33 4					SDR 26 5					SDR 21 6							
PE 100		4			5			6			8			8								
OD	min	max	WALL THICKNESS		NOM ID	MASS Kg/M	min	Avg	max	NOM ID	MASS Kg/M	min	Avg	max	WALL THICKNESS	min	Avg	max	NOM ID	MASS Kg/M		
			min	Avg																		
16		16.3																				
20		20.3																				
25		25.3																				
32		32.3																				
40		40.3																				
50		50.3																				
63		63.4																				
75		75.5																				
90		90.6																				
110		110.7																				
125		125.8																				
140		140.9																				
160		161																				
180		181.1																				
200		201.2																				
225		226.4																				
250		251.5																				
280		281.7																				
315		316.9	7.7	8.15	8.6	299.7	7.550	9.7	10.25	10.8	295.5	9.430	12.1	12.8	13.5	290.4	11.678	15	15.8	16.6	284.4	14.273
355		357.2	8.7	9.2	9.7	337.7	9.605	10.9	11.5	12.1	333.1	11.927	13.6	14.35	15.1	327.4	14.760	16.9	17.8	18.7	320.5	18.123
400		402.4	9.8	10.35	10.9	380.5	12.175	12.3	13	13.7	375.2	15.188	15.3	16.15	17.0	368.9	18.716	19.1	20.15	21.2	360.9	23.109
450		452.7	11	11.6	12.2	428.2	15.352	13.8	14.55	15.3	422.3	19.128	17.3	18.2	19.1	415.0	23.664	21.5	22.65	23.8	406.1	29.224
500		503	12.3	13	13.7	475.5	19.113	15.3	16.15	17	469.2	23.591	19.1	20.15	21.2	461.2	29.191	23.9	25.15	26.4	451.2	36.056
560		563.4	13.7	14.45	15.2	532.8	23.800	17.2	18.15	19.1	525.4	29.691	21.4	22.55	23.7	516.6	36.591	26.7	28.1	29.5	505.5	45.127
630		633.8	15.4	16.25	17.1	599.4	30.109	19.3	20.35	21.4	591.2	37.455	24.1	25.4	26.7	581.1	46.364	30	31.55	33.1	568.8	57.006
710		716.4	17.4	18.35	19.3	675.3	38.374	21.8	22.95	24.1	666.1	47.676	27.2	28.65	30.1	654.7	59.026	33.9	35.65	37.4	640.7	72.697
800		807.2	19.6	20.65	21.7	760.7	48.660	24.5	25.8	27.1	750.4	60.395	30.6	32.2	33.8	737.6	74.757	38.1	40.1	42.1	721.8	92.144
900		908.1	22	23.15	24.3	855.7	61.375	27.6	29.05	30.5	843.9	76.501	34.4	36.35	38.3	829.3	94.927	42.9	45.1	47.3	811.8	116.590
1000		1009.0	24.5	25.8	27.1	950.4	75.995	30.6	32.05	33.5	937.9	93.802	38.2	40.2	42.2	921.6	116.668	47.7	50.15	52.6	901.7	144.043

AVAILABLE HDPE COILS

COIL DIMENSIONS			ID			OD			Width (W)					Weight				
Di	PN	Kg/m	mm	mm	m	mm	mm	mm	mm	mm	mm	mm	mm	mm	mm	kg	kg	kg
110	10	2.177	1800	2240	2460	2460	2460	2460	2460	2460	2460	2460	2460	2460	2460	110	163	218
110	12.5	2.634	1800	2240	2460	2460	2460	2460	2460	2460	2460	2460	2460	2460	2460	110	198	263
110	16	3.169	1800	2240	2460	2460	2460	2460	2460	2460	2460	2460	2460	2460	2460	110	238	317
125	10	2.777	1800	2300	2550	2550	2550	2550	2550	2550	2550	2550	2550	2550	2550	125	209	279
125	12.5	3.394	1800	2300	2550	2550	2550	2550	2550	2550	2550	2550	2550	2550	2550	125	256	341
125	16	4.111	1800	2300	2550	2550	2550	2550	2550	2550	2550	2550	2550	2550	2550	125	310	413
140	12.5	4.250	2000	2560	2560	2560	2560	2560	2560	2560	2560	2560	2560	2560	2560	140	320	N/A
140	16	5.124	1800	2360	2640	2640	2640	2640	2640	2640	2640	2640	2640	2640	2640	140	387	512
160	12.5	5.547	2000	2640	2640	2640	2640	2640	2640	2640	2640	2640	2640	2640	2640	160	418	N/A
160	16	6.725	1700	2340	2660	2660	2660	2660	2660	2660	2660	2660	2660	2660	2660	160	506	672
180	16	8.500	1700	2420	2420	2420	2420	2420	2420	2420	2420	2420	2420	2420	2420	180	638	N/A

HOT DIPPED GALVANISED BACKING RINGS

PIPE OD	BS 4504 10/3 - SABS 1123 1000/3									BS 4504 16/3 - SABS 1123 1600/3								
	DIMENSIONS					BOLTS				DIMENSIONS					BOLTS			
	D	d1	b	PCD (k)	Qty	d2	P-P	P-S	D	d1	b	PCD (k)	Qty	d2	P-P	P-S		
20	95	30	10	65	4	M12	65	50	95	30	10	65	4	M12	65	50		
25	105	38	10	75	4	M12	65	50	105	38	10	75	4	M12	65	50		
32	115	45	10	85	4	M12	65	50	115	45	10	85	4	M12	65	50		
40	140	52	10	100	4	M16	80	60	140	52	10	100	4	M16	80	60		
50	150	63	10	110	4	M16	80	60	150	63	10	110	4	M16	80	60		
63	165	74	12	125	4	M16	90	65	165	74	12	125	4	M16	90	65		
75	185	86	12	145	4	M16	90	65	185	86	12	145	4	M16	90	65		
90	200	103	12	160	8	M16	90	65	200	103	14	160	8	M16	90	65		
110	220	136	12	180	8	M16	100	70	220	136	14	180	8	M16	100	70		
125	220	136	12	180	8	M16	120	80	220	136	14	180	8	M16	120	80		
140	250	158	14	210	8	M16	120	90	250	158	16	210	8	M16	120	90		
160	285	190	16	240	8	M20	130	90	285	190	18	240	8	M20	130	90		
180	285	190	16	240	8	M20	140	100	285	190	18	240	8	M20	140	100		
200	340	237	18	295	8	M20	140	100	340	237	22	295	12	M20	150	100		
225	340	237	20	295	8	M20	150	110	340	237	22	295	12	M20	160	120		
250	395	279	18	350	12	M20	160	120	405	279	22	355	12	M24	170	120		
280	395	292	20	350	12	M20	160	120	405	292	25	355	12	M24	170	130		
315	445	330	22	400	12	M20	190	130	460	330	28	410	12	M24	190	140		
355	505	376	25	460	16	M20	190	140	520	376	30	470	16	M24	200	150		
400	565	430	25	515	16	M24	210	150	580	430	35	525	16	M24	240	170		
450	615	476	30	565	20	M24	240	160	640	476	40	585	20	M24	250	180		
500	670	533	30	620	20	M24	240	160										
560	730	592	35	675	20	M24	240	170										
630	835	662	36	725	20	M24	260	180										
710	895	737	40	840	24	M24	250	180										
800	1015	840	45	950	24	M30	280	210										
900	1115	942	50	1050	28	M30	310	240										
1000	1230	1045	55	1160	28	M30	340	250										

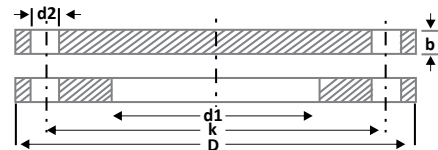

PIPE OD	BS 10 TABLE "D"									ASA 150								
	DIMENSIONS					BOLTS				DIMENSIONS					BOLTS			
	D	d1	b	PCD (k)	Qty	d2	P-P	P-S	D	d1	b	PCD (k)	Qty	d2	P-P	P-S		
20	95.3	30	5	66.7	4	M12	55	40	88.9	30	10	60.3	4	M12	65	50		
25	101.6	38	5	73	4	M12	55	40	98.4	38	10	69.8	4	M12	65	50		
32	114.3	45	5	82.6	4	M12	55	40	107.9	45	10	79.4	4	M12	65	50		
40	120.7	52	6	87.3	4	M12	75	60	117.5	52	12	88.9	4	M12	90	65		
50	133.4	63	6	98.4	4	M12	75	60	127	63	12	98.4	4	M16	90	65		
63	152.4	74	8	114.3	4	M16	80	55	152.4	74	12	120.6	4	M16	90	65		
75	165.1	86	8	127	4	M16	80	55	177.8	86	12	139.7	4	M16	90	65		
90	184.1	103	10	146	4	M16	80	60	190.5	103	12	152.4	4	M16	90	65		
110	215.9	136	10	177.8	4	M16	100	70	228.6	136	15	190.5	8	M16	110	80		
125	215.9	136	10	177.8	4	M16	110	75	228.6	136	15	190.5	8	M16	120	90		
140	254	158	13	209.6	8	M16	120	80	254	158	15	215.9	8	M20	120	90		
160	279.4	190	13	235	8	M16	120	90	279.4	190	20	241.3	8	M20	140	100		
180	279.4	190	13	235	8	M16	130	90	279.4	190	20	241.3	8	M20	150	110		
200	336.6	237	13	292.1	8	M16	130	90	342.9	237	20	298.4	8	M20	150	110		
225	336.6	237	13	292.1	8	M16	140	100	342.9	237	20	298.4	8	M20	160	110		
250	406.4	279	16	355.6	8	M20	150	110	406.4	279	25	361.9	12	M24	170	130		
280	406.4	292	16	355.6	8	M20	150	110	406.4	292	25	361.9	12	M24	170	130		
315	457.2	330	19	406.4	12	M20	180	130	482.6	330	30	431.8	12	M24	220	150		
355	527.1	376	22	469.9	12	M24	190	130	533.4	376	30	476.2	12	M24	200	150		
400	577.9	430	22	520.7	12	M24	210	140	596.9	430	30	539.7	16	M24	220	160		
450	641.4	476	25	584.2	12	M24	220	150	635	476	30	577.8	16	M30	240	160		
500	704	533	29	641.4	16	M24	240	160	698.5	533	30	635	20	M30	240	160		
560	825.5	592	30	755.7	16	M24	240	160	812.8	592	35	749.3	20	M32	240	170		
630	825.5	662	32	755.7	16	M24	250	170										
710	908.1	737	35	844.6	20	M24	240	170										
800	-	-	-	-	-	-	-	-										
900	1174.7	942	48	1092.2	24	M32	310	220										
1000	1257.3	1045	51	1174.7	24	M32	330	240										

NOTE: The bolt diameters and length refer to flanges drilled to the above standard only - length of bolts allow for washers and gaskets. (All dimensions tabled in millimetres - mm)



rare plastics

A Division of the Rare Group

FITTING DIMENSIONS

Fittings can be manufactured in a wide variety of Diameters and pressure ratings (PN). The most popular diameters begin from 75mm (OD) and PN 6 or higher. Permissible working pressure is 60% of the nominal pressure of the pipe used to fabricate the fitting. E.g. A PN10 pipe yields a PN6 fabricated fitting.

SEGMENTED BENDS

90° Bend

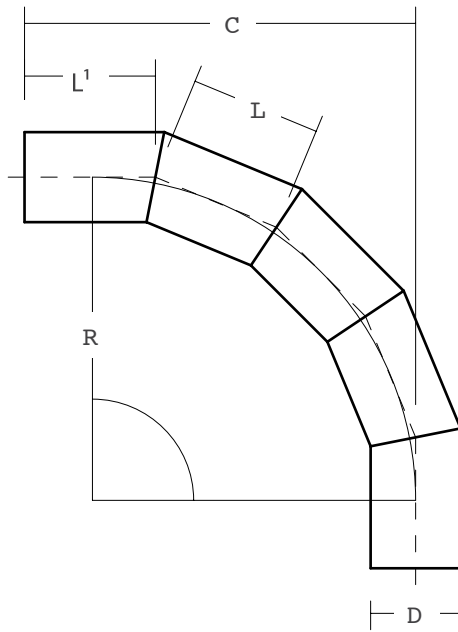

OD mm (D)	L mm	C mm	L' mm	R mm
110	155	478	160	395
125	155	478	160	395
140	155	478	160	395
160	155	478	160	395
180	155	478	160	395
200	250	279	280	367
225	250	279	280	367
250	250	279	280	367
280	250	279	280	367
315	250	279	280	367
355	380	1178	400	968
400	380	1178	400	968
450	380	1178	400	968
500	380	1178	400	968
560	470	1450	560	1350
630	590	1800	600	1520

45° Bend

OD mm (D)	L mm	L' mm	R mm
110	155	238	395
125	155	238	395
140	155	238	395
160	155	238	395
180	155	238	395
200	250	405	637
225	250	405	637
250	250	405	637
280	250	405	637
315	250	405	637
355	380	590	968
400	380	590	968
450	380	590	968
500	380	590	968
560	470	900	1200
630	590	900	1500

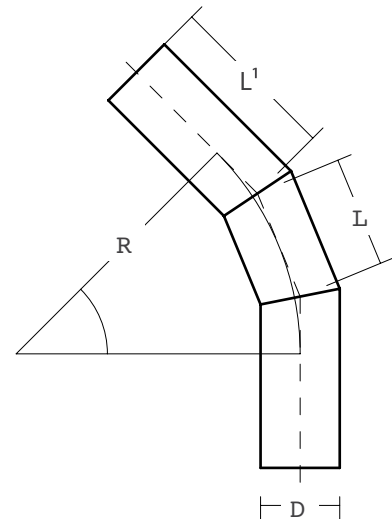



rare plastics

A Division of the Rare Group

SEAMLESS BENDS

45° and 90°

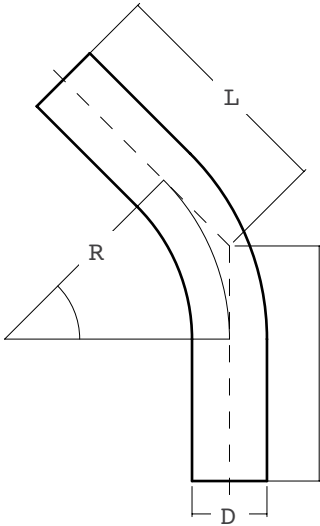

OD mm (D)	R mm	45° mm (L)	90° mm (L)
110	330	345	535
125	375	360	580
140	420	380	625
160	480	405	685
180	540	430	745
200	600	455	805
225	675	485	880
250	750	515	955
280	840	555	1045
315	945	585	1150
355	1065	645	1270
400	1200	705	1405
450	1350	765	1555

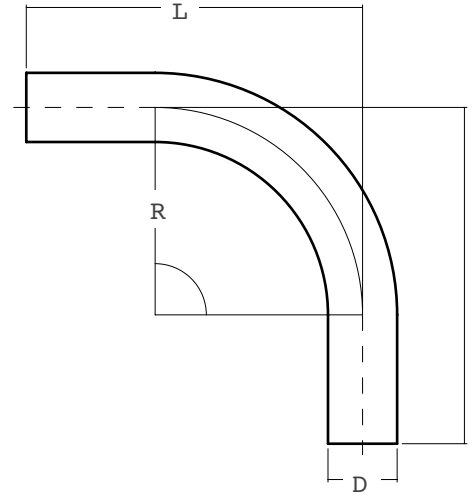

Sizes 110mm - 280mm: 2D Radius | 315mm - 450mm: 3D Radius

Minimum of PN10/SDR 17 for sizes 160mm and greater | Minimum of PN16/SDR 11 for smaller sizes.

TEES

OD mm (D)	H mm	L mm
90	200	400
110	455	910
125	465	930
140	470	940
160	480	960
180	490	980
200	500	1000
225	515	1030
250	525	1050
280	740	1480
315	760	1520
355	780	1560
400	800	1600
450	925	1850
500	950	1900
560	1180	2360
630	1215	2430

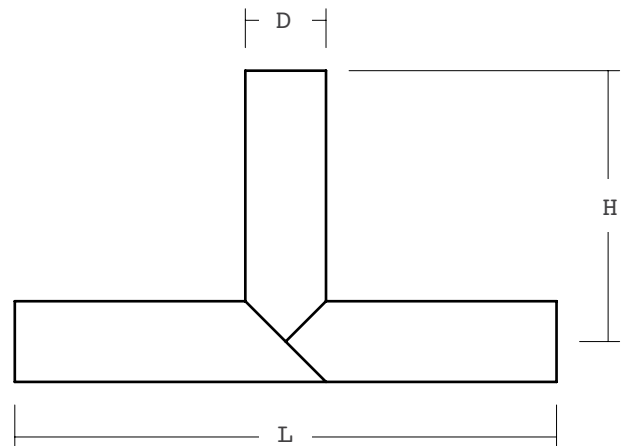



rare plastics

A Division of the Rare Group

LATERAL PLAIN ENDED

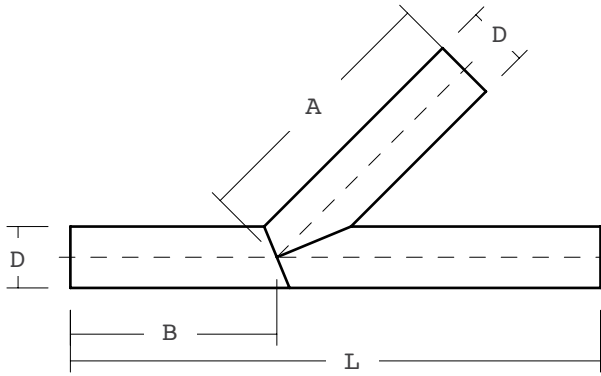

OD mm (D)	A mm	B mm	L mm
50	200	150	400
63	200	150	400
75	475	370	950
90	475	370	950
110	475	370	950
125	475	370	950
140	475	370	950
160	475	370	950
180	875	530	1350
200	875	530	1350
225	875	530	1350
250	875	530	1350
280	900	700	1800
315	900	700	1800
355	900	700	1800
400	900	700	1800
450	1100	870	2200

MACHINED REDUCING BUSHES

OD mm (D ¹)	OD mm (D ²)	L mm
25	20	60
32	20/25	60
40	20/25/32	60
50	25/32/40	60
63	25/32/40/50	60
75	32/40/50/63	60
90	40/50/63/75	60
110	63/75/90	60
125	75/90/110	60
140	90/110/125	80
160	90/110/125/140	80
180	110/125/140/160	80
200	140/160/180	80
225	160/180/200	80
250	180/200/225	80
280	200/225/280	80
315	250/280	80
355	280/315	90
400	315/355	90
450	355/400	90
500	400/450	90

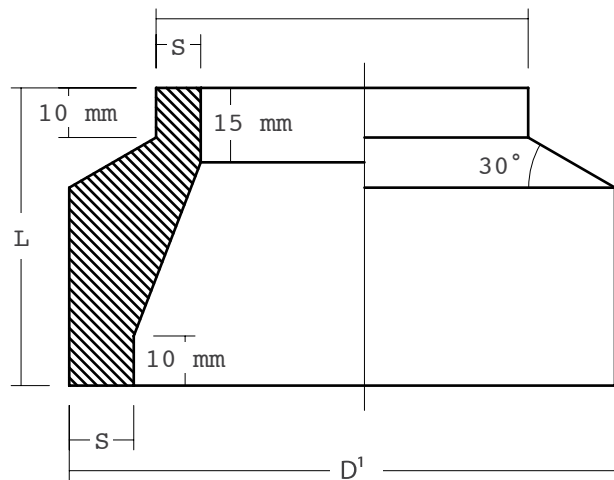



rare plastics

A Division of the Rare Group

STUB FLANGE DETAIL

PIPE OD	D	A	D ²	PN 4 - 10		PN 12 - 25	
				B	H	B	H
16	46	10	28	15	40	15	40
20	46	10	28	15	40	15	40
25	56	10	36	15	40	15	40
32	65	10	43	20	40	27	60
40	73	10	50	20	50	27	60
50	83	10	60	20	50	27	60
63	98	10	71	20	50	27	60
75	110	10	83	20	50	27	60
90	129	10	100	20	50	27	60
110	158	10	125	25	55	35	75
125	160	10	133	30	60	35	75
140	188	10	155	30	60	35	75
160	217	10	187	35	70	55	100
180	217	10	187	35	70	55	100
200	270	10	234	35	70	55	100
225	270	10	234	45	80	55	100
250	310	10	275	45	80	75	120
280	325	10	289	45	80	75	120
315	375	10	327	50	90	75	120
355	430	10	373	50	90	75	120
400	486	10	426	60	100	75	120
450	540	10	472	60	100	75	120
500	585	10	526	60	100	-	-
560	645	10	588	65	105	-	-
630	725	10	658	65	105	-	-

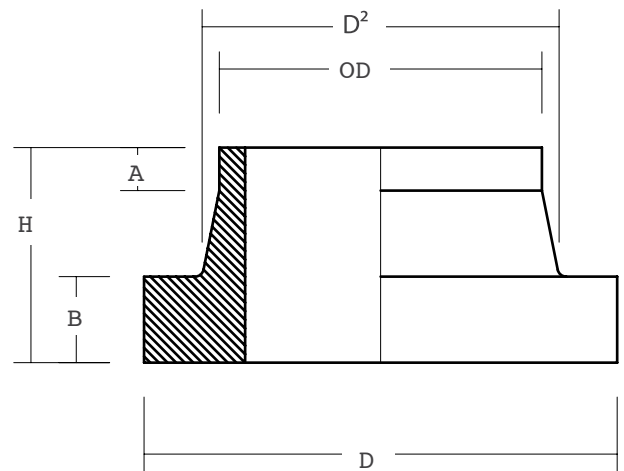



rare plastics

A Division of the Rare Group

TAK-STUB DETAIL

PIPE OD	D	TYPE L	TYPE H
		<400 Kpa W (mm)	<1600 Kpa W (mm)
110	142	-	53
125	167	-	55
140	175	-	60
160	196	52,5	65
180	224	65	65
200	246	-	68
225	272	-	74
250	297	78	75
280	326	-	78

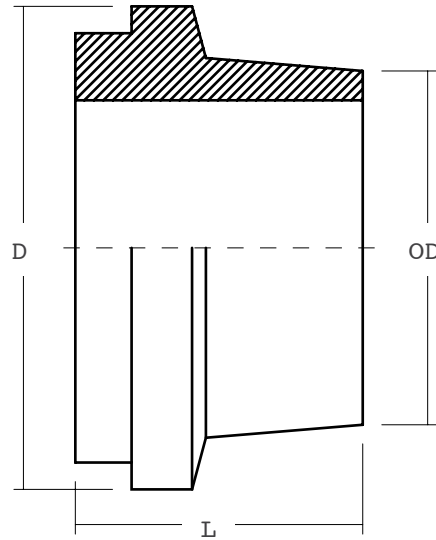

VICTAULIC STUB DETAIL

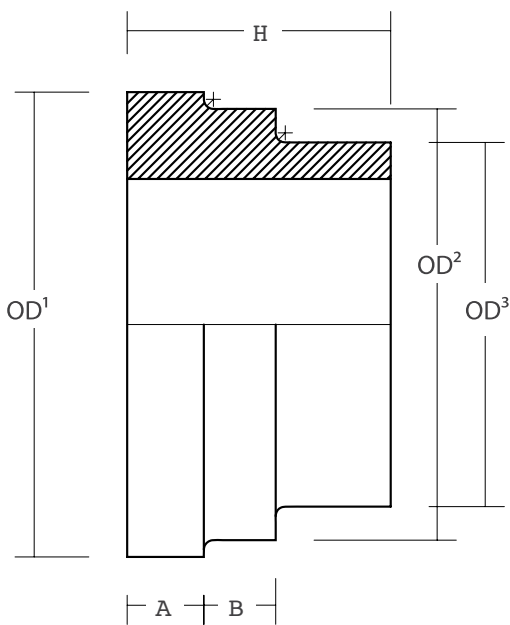

PIPE OD	VICTAULIC SIZE	OD¹	OD²	OD³	A	B	H	CLAMP SIZE
50	63	68,5	60	50,5	16	10	55	2"
63	90	97	90	61	16	15	55	3"
75	90	97	90	76	16	15	55	3"
90	110	124,5	115	91	16,5	15	55	4"
110	110	124,5	115	111	16,5	15	55	4"
125	160	178,5	161	126	17	15	55	6"
140	160	178,5	161	141	17	15	55	6"
160	160	178,5	161	161	17	15	55	6"
180	225	231,5	218	181	21	21	85	8"
200	225	231,5	218	201,5	21	21	85	8"
225	250	286	273	226,5	21	21	85	10"
250	250	286	273	251,5	21	21	85	10"

RARE RPC

(Rare Plastics Co-Extruded) Pipes for Water & Sewer

Rare Plastics, in conjunction with its technology partner Borealis, has produced a water and sewer pipe specifically for AIT (Alternative Installation Techniques). This polymer technology has high resistance to slow crack growth and point loads, compared to standard PE100.

RPC is a three layer co-extruded pipe with outer and inner layers of advanced PE100-RC polymer and a PE100 core as shown below. The outer and inner layers are blue PE100-RC polymer and the remaining core is black PE100. The three layers are fused together during manufacture and inseparably extruded.

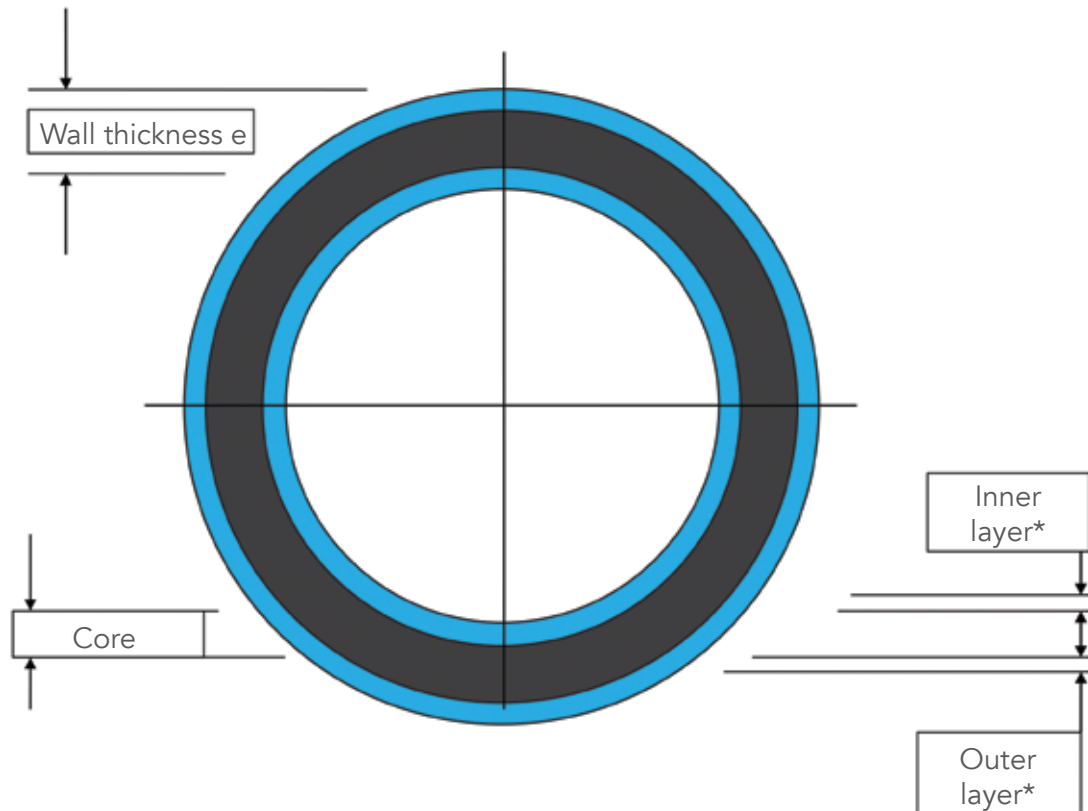

* Minimum of 2,5 mm as per PAS 1075

PE100-RC

This is a specifically developed advanced polymer that resists the effects of notches, scores, scratches, grooves and point loads that may result from the trenchless installation technique used or installation without selected or imported bedding and embedding material.

PIPES MANUFACTURED USING PE100-RC MATERIAL MUST PASS DEMANDING TESTS AS FOLLOWS:

The Notch Test (ISO 13479)	FNCT (Full Notch Creep Test (ISO 16770)	CT (Cone Test)	PLT (Point Loading Test)	PAS (Publicly Available Specification) 1075 requires:
tests SCG (Slow Crack Growth) at 4.6 MPa stress and 80° Celsius temperature and must not fail before 8,760 hours (1 year)	tests SCG at 4.0 MPa stress and 80° Celsius temperature in a 2% Arkopal solution and must not fail before 8,760 hours (1 year)	measures time for crack formation and crack propagation	in 2% Arkopal solution at 80° Celsius with a 10 mm diameter piston pressed into the wall of the pipe at yield stress (4N/mm ²) and maintained until failure. Failure time is greater than 5 times PE100 time and the correlation between FNCT and PLT shows a pipeline life expectancy of about 100 years when installed without embedment (bedding and surrounding).	FNCT (ISO 16770) >8,760 hours; PLT >8,760 hours; Notch Test (ISO 13479) >8,760 hours; FNCT and PLT correlation – 8,760 and 3,300 hours.

Please see the "Trenchless Technology" Specification on the Centre of Expertise website for a comprehensive specification of PE-100-RC and PAS 1075 for more details of the above tests.

PE100-RC AND PE100

The superior properties of PE100-RC compared with standard (ISO/SANS 4427) PE100 are as follows:

TEST	PE100 - hours	PE100-RC - hours
Notch test	2,200	11,580
FNCT	1,600	8,552*
Point load test	2,200	>9,000

*NB: The failure was ductile not brittle

ALTERNATIVE INSTALLATION METHODS REQUIRING RPC

TWO ONEROUS DEMANDS MAY BE MADE ON THE PIPES AS FOLLOWS:

- ▶ Outside damage such as notches, scores, scratches and grooves caused by pulling the pipeline.
- ▶ Point loading caused by hard objects impinging on the pipe.

Installation method	Point loads	Crack initiation	Notch
Directional drilling	XXX	XXX	XXX
Pipe bursting	XX	XXX	XXX
Swagelining	XX	XX	XX
Close fit	X	XX	XX
Slip lining	X	X	XX
No imported bed	XXX	X	-

X – Indicates the probability of damage occurring and protection needed.

JOINING RPC PIPES

TWO METHODS OF JOINING THE PIPES MAY BE USED AS FOLLOWS:

- ▶ Butt welding – the machinery, procedures and techniques are the same as those for standard PE100 polymer pipes.
- ▶ Electro-fusion – the machinery, procedures and techniques are the same as those for standard PE100 polymer pipes and can be welded to both PE80 and PE100 fittings.

RPC pipes are compatible with standard PE100 polymer pipes and can be joined with standard jointing methods such as butt welding and electro-fusion.



Handling, storage and transportation

As SAPPMA members we suggest referring to the SAPPMA technical manual.

Accreditations

The latest revisions of accreditations can be found on our website or provided on request.



rare plastics

A Division of the Rare Group

4 Meyer St, Meyerton
 PO Box 124186, Alrode, 1451
GPS: S 26°34.018' E028°00.381'

Tel: +27 16 362 2868
Fax: +27 16 362 0732
Email: info@rare.co.za
Web: www.rare.co.za

DISCLAIMER:

Whilst every care has been taken in the preparation of this brochure, neither **Rare Plastics** nor any of their agencies can be held liable for any errors in this publication. It should also be noted that this brochure is intended or reference only. Due consultation is required when designing for particular applications, and no liability will be entertained in this regard.